

THE LONDON GAS PATIO HEATER



Heat Outdoors Ltd
Unit 9 Stort Valley Industrial Estate
Stansted Road
Bishop's Stortford
Hertfordshire
CM23 2TU

www.heat-outdoors.co.uk



WARNING



- This patio heater is for outdoor use only.
- Use only Liquid Petroleum Gas (LPG).
- Children should be carefully supervised when they are in the area of the heater.
- Do not spray aerosols in the vicinity of this appliance.



WARNING



- Turn off the gas valve immediately if a smell of gas is detected.
- Extinguish any open flames.
- Close the valve of the gas cylinder or the regulator after use.
- The use of this appliance in enclosed areas can be dangerous and is PROHIBITED.



WARNING



The user assumes all risk in the assembly and operation of the gas heater. Failure to follow the warnings and instructions in this manual can result in severe personal injury, death or property damage. If you cannot read or fully understand the instruction manual, please contact your retailer.



WARNING



- Read the instructions before installation and use.
- This appliance must be installed and the gas cylinder stored in accordance with regulations in force.
- Shut off the valve at the gas cylinder or the regulator before moving the appliance.
- Use only the type of gas and the type of cylinder specified by the manufacturer.
- In case of violent wind particular attention must be taken against tilting of the appliance.
- Keep the instructions for future reference.

CAUTION

PLEASE READ THE FOLLOWING SAFETY GUIDELINES CAREFULLY BEFORE OPERATION.

- This outdoor heater is not intended to be installed on recreational vehicles and/or boats.
- Improper installation, adjustment, alteration can cause personal injury and/or property damage.
- Do not attempt to alter the unit in any manner.
- Remove packing materials before use.
- Plumbing tape must be used for all threaded gas connections to prevent leakage.
- The whole gas system, hose, regulator, pilot and burner should be inspected for leaks or damage before use.
- All leak tests should be done with a soapy water solution. Never use an open flame to check for leaks.
- Do not use the heater until all connections have been leak tested.
- Turn off the gas valve immediately if a smell of gas is detected.
- Do not transport the heater while it's operating or still hot.
- Do not move the heater after it has been turned off until the temperature has cooled down.
- Keep the ventilation opening of the cylinder enclosure free and clear of debris.
- Do not paint the radiant screen, control panel or top canopy reflector.
- Control compartment, burner and circulation air passageways of the heater must be kept clean.
- Frequent cleaning may be required as necessary.
- The gas cylinder should be turned off when the heater is not in use.
- Check the heater immediately if any of the following occurs:
 - The heater does not reach temperature.
 - The burner makes popping noise during use (a slight noise is normal when the burner is extinguished).
 - Smell of gas in conjunction with extreme yellow tipping of the burner flames.
- Avoid inhaling fumes emitted from the heater's first use. Smoke and odour from the burning of oils used in manufacturing will appear. Both the smoke and odour will dissipate after approximately 30 minutes.
- The hose assembly must be located out of pathways where people may trip over it.
- Any guard or other protective device removed for servicing the heater must be replaced before operating the heater.
- Adults and children should stay away from high temperature surfaces to avoid burns.
- The minimum distances from non protected combustible materials should be 1 meter.
- Change the gas cylinder in an amply ventilated area, away from any ignition source (candle, cigarettes, other flame producing appliances).
- Check that the regulator seal is correctly fitted and able to fulfill its function.

HEATER LOCATION

- The heater is for outdoor use only or in amply ventilated areas (see diagrammatical representations of outdoor areas below). Do not use it indoors or in an enclosed area. Always ensure that adequate ventilation is provided.
- Any enclosure in which the appliance is used shall comply with one of the following:
 - An enclosure with walls on all sides, but at least one permanent opening at ground level and no overhead cover.
 - Within a partial enclosure that includes an over head cover and no more than two walls.
 - Within a partial enclosure that includes an overhead cover and more than two walls, the following shall apply:
 - At least 25% of the total wall area is completely open, and
 - At least 30% of the remaining wall area is open and unrestricted.
- Heater must be placed on level firm ground.
- Never operate heater in areas where gasoline or other flammable liquids or vapors are stored.
- To protect heater from strong winds, anchor the base securely to the ground with screws, stakes, or other suitable fasteners.

Warning:

- 1) For use outdoors or in amply ventilated areas
- 2) An amply ventilated area must have a minimum of 25 % of the surface area open.
- 3) The surface area is the sum of the walls surface.

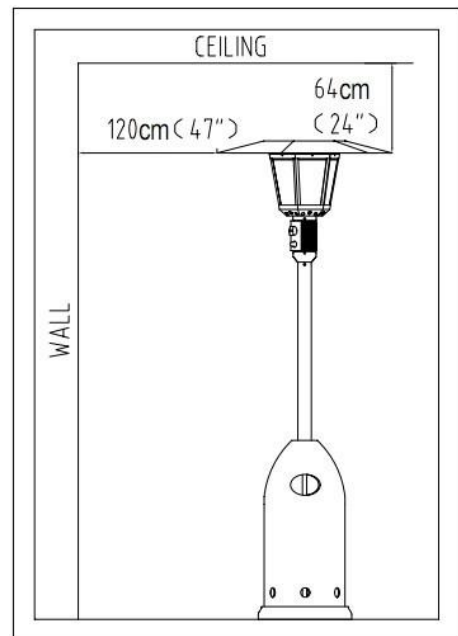
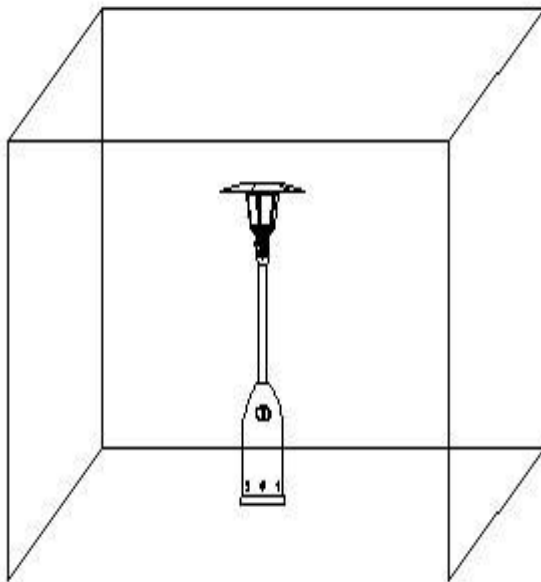

- Always maintain clearance from combustible materials, from the top 64cm and sides 120cm.

GAS REQUIREMENTS

- Cylinder should be a maximum 15KG.
- Using 37mbar propane outlet regulator for category I3+;
- Please check gas hose at least once per month and each time the cylinder is changed. If it shows any signs of cracking, splitting or other deterioration exchange it for new hose of the same length and of an equivalent quality
- A dented, rusted or damaged gas cylinder may be hazardous and should be checked by your gas supplier. Never use a gas cylinder with a damaged valve connection.
- Avoid twisting the flexible tubes and hoses.
- Never connect an unregulated gas cylinder to the heater.
- Disconnect the gas cylinder when the heater is not use.

LEAKAGE TEST

Gas connections on the heater are leak tested at the factory prior to shipment. However, a complete gas tightness check must also be performed at the installation site. The heater must be checked with a full gas cylinder.

1. Make sure the safety control valve is in the OFF position.
2. Make a soapy water solution of one part liquid dish detergent and one part water. The soapy water solution can be applied with a spray bottle, brush or rag to all gas connections.
3. Turn the gas supply ON at the cylinder.
4. Growing soap bubbles will appear in case of a leak.
5. In case of a leak, turn off the gas supply at the cylinder. Tighten any leaking fittings, then turn the gas supply ON and recheck. Contact your gas supplier for assistance if bubbles continue to appear.



WARNING

Never leak test while smoking.

In the event of gas leakage, the appliance shall not be used or if alight, the gas supply shall be shut off and the appliance shall be investigated and rectified before it is used again.

Check all gas connections with bubbles, half water and half detergent, before every time use.

PARTS AND SPECIFICATIONS

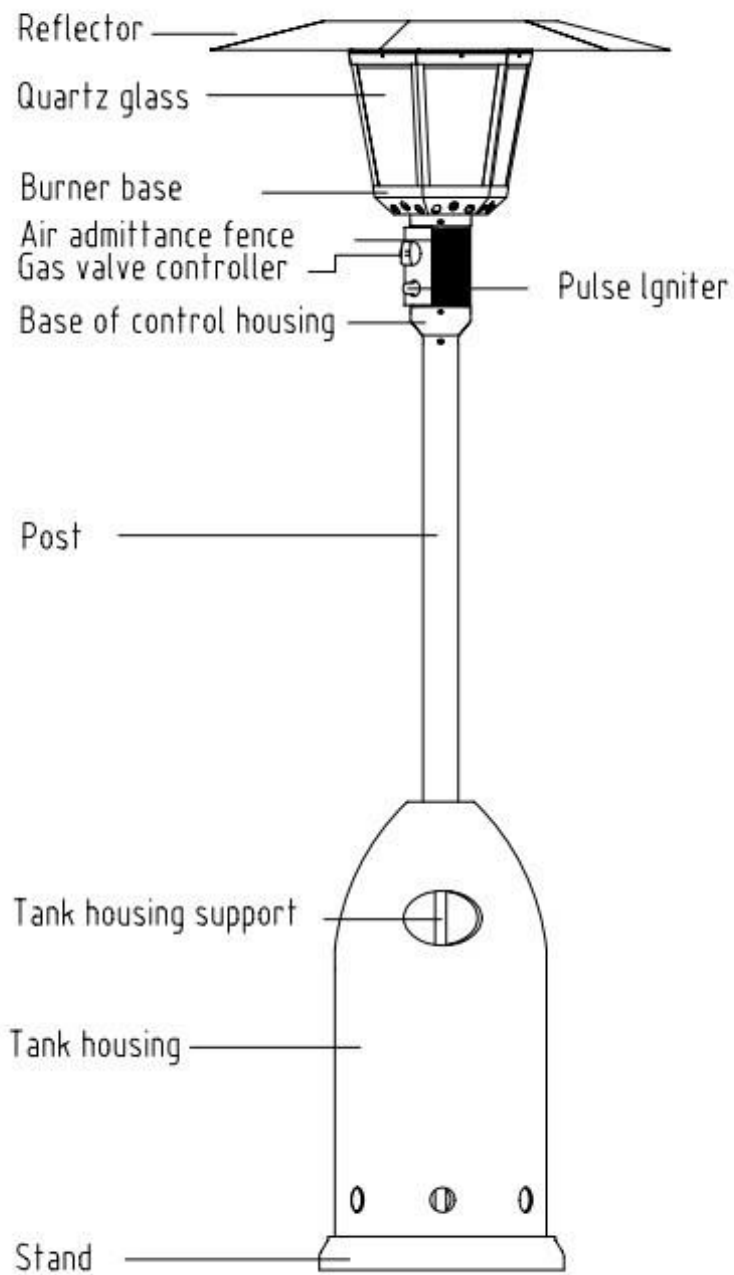

ASSEMBLY PARTS

(Not Supplied)

- Adjustable opening wrench (2) 20 cm (8") long
- Long nosed pliers 23 cm (9") long
- Philips screwdriver w/ medium blade
- Spray bottle of soap solution for leakage test

Parts supplied:

- Tank housing
- Stand with tank housing support
- Assembly post with 3 pcs post brackets
- 1 pcs Reflector with 1 pcs M8 nuts
- 4 pcs bolts M6 x 10 mm for assembly post and burner
- 6 pcs bolts & nuts M6 x 35 mm for post and post brackets
- 3 pcs bolts M8 x 16 mm for post brackets and stand
- 3 pcs ground fixture kit
- 6 pcs M6 x 10 mm ground fixer bolts & nuts
- 2 pcs bolts M8 x 10 mm for wheel assembly
- 1 set bracket with wheels

ASSEMBLY PROCEDURES

STEP 1

- 1-1. As shown, put three support bars respectively in position on chassis;
- 1-2. Connect the support bars to the chassis with three M8 x 15 mm screws.
- 1-3. Place the support bar with the gas cylinder strap at the rear, wheel side.

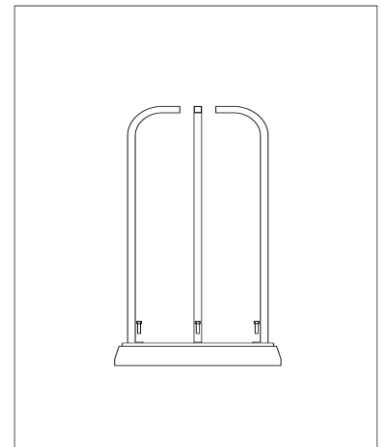

STEP 2

- 2-1. Place the main stand post above the three support bars;
- 2-1. Connect the main post and support bars together with six M6 x 35 mm screws and 6 mm diameter nuts and tighten.

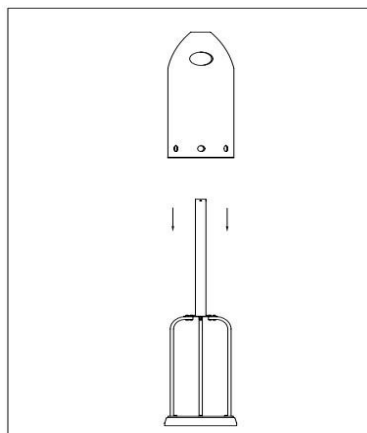

STEP 3

Place the tank housing on the stand.

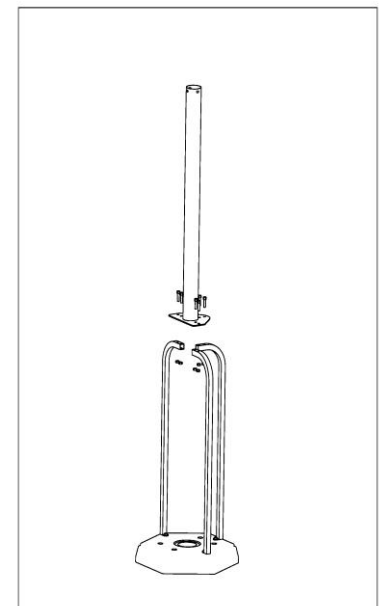

STEP 4

Tighten the aluminum reflector with M8*50 screw

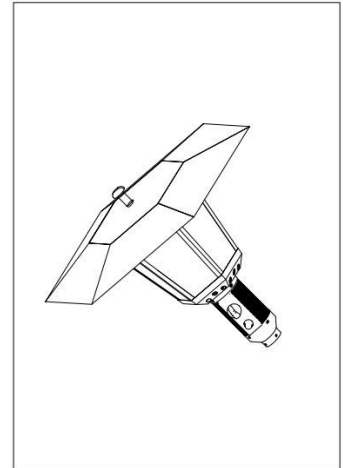

STEP 5

5-1. Feed Orange gas tube up the centre pole on the stand, and attached to the base of the heater head; ensuring the hose is fully on and secured with enclosed jubilee clip.

5-2. Place the heating head on top of support tube and attach with four M6 x 10 screws.

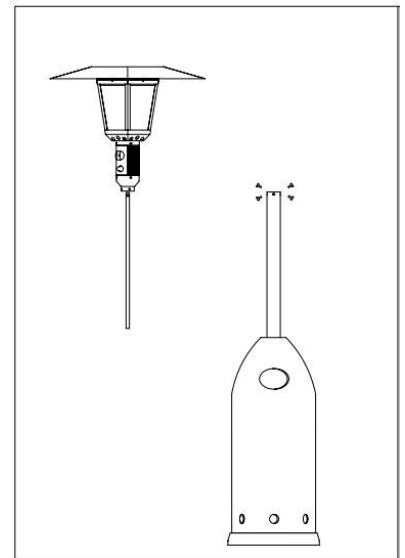

STEP 6

6-1. Lift the base cover;

6-2. Connect the rubber hose on the gas regulator valve and also the gas feed tube, and tighten the two jubilee clips;

6-3 Connect the regulator to an approved LPG/Propane gas bottle

6-4. Replace the cover.

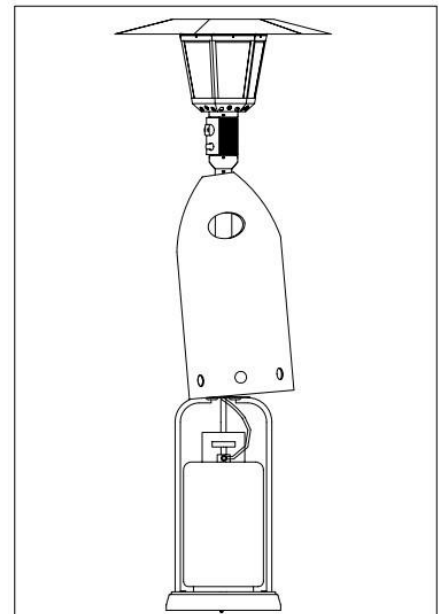

Step 7

7-1 Unscrew plastic black ring around ignition switch to remove it and insert AAA battery as shown below
7-2 Screw ignition switch and battery back into heater



OPERATION

TO TURN ON THE HEATER

1. Turn on the valve on the gas supply cylinder.
2. Press and turn the control knob to PILOT position (counter-clockwise 90°).
3. Press down the control knob and hold for 30 seconds. While holding down the control knob, press the igniter button until the pilot flame ignites. Release the control knob 20~30 seconds after the ignition.

Note:

- If a new tank has just been connected, please allow at least one minute or more for the air in the gas pipeline to purge out.
 - Pilot flame can be watched and checked from the peephole located on the base of burner.
 - If the pilot flame does not light or it goes out, repeat step 3.
4. Turn the control knob to LO and leave it there for 5 minutes or more before turning the knob to desired temperature setting.
 5. If the burner flame goes out accidentally or it is blown out by wind, turn off the heater and wait at least 5 minutes or more to let the gas dissipate before re-lighting to avoid possible gas explosion. Repeat steps 2 to 4.

TO TURN OFF THE HEATER

1. Turn the control knob to PILOT position.
2. Press and turn the control knob to OFF position.
3. Turn off the valve on the gas cylinder and disconnect the cylinder.

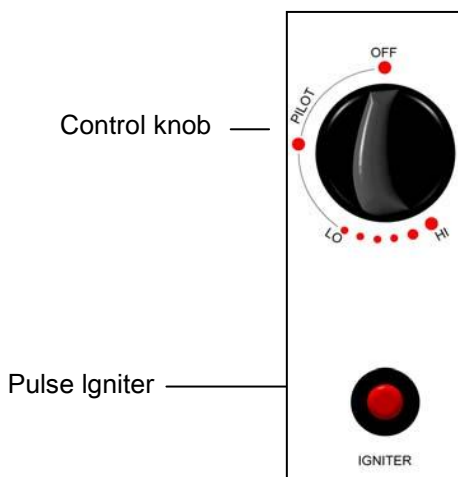

WARNING

1. The whole gas system, hose, regulator, pilot and burner should be inspected for leaks before use.
2. Check the hose assembly for sign of abrasion, cuts or wear. Suspected areas should be leak tested. If the hose leaks, it must be replaced.
3. Avoid twisting the flexible tubes and hoses.
4. Make sure the ventilation opening of the cylinder enclosure, control compartment, burner and circulation air passageways of the heater are free and clear of debris. If debris, spider or insect nests are found, clean the holes with a heavy-duty pipe cleaner or compressed air.
5. Always keep a dry chemical fire extinguisher readily available.
6. For safety, always allow a 5-minute complete shut off period before re-lighting a hot heater.

WARNING



Do not move the heater or cover it with protective cover right after it has been turned off, wait until the temperature has completely cooled down.

REPLACING THE GAS CYLINDER

1. Close the valve of the gas cylinder.
2. Disconnect the regulator from the cylinder following the instructions that came with your regulator.
3. Replace the cylinder.
4. In the absence of any flame, remove the plug or seal cap from the cylinder valve.
5. Check for the presence and good state of the gasket before connecting the regulator.
6. Perform leak test using soapy water solution.

WARNING

1. Changing of cylinder must be undertaken in a flame-free atmosphere.
2. Make sure that gas taps on the consuming appliance are in closed position.

STORAGE

- **Always close the valve of the gas cylinder after use or in case of a disturbance.**
- Remove the pressure regulator and the hose attachment if the heater is not to be used for a period of time.
- Cylinder must be stored outdoors in a well-ventilated area out of the reach of children.
- Disconnected cylinder must have threaded valve plugs tightly installed and must not be stored in garage or any other enclosed area.
- Storage of heater indoors is permissible only if the cylinder is disconnected and removed from the heater.
- Check the tightness of the gas valve and for damage. If you suspect damage, have it changed by your gas dealer.
- Never store liquid gas cylinder in a sub-terrain, or at places without adequate air ventilation.

CLEANING AND CARE

- Wipe off powder coated surfaces with soft, moist rag and soapy water. Do not clean heater with cleaners that are combustible or corrosive.
- Remove debris, spider and insect nests from ventilation opening of the cylinder enclosure, control compartment, burner and circulation air passageways of the heater with heavy-duty pipe cleaner or compressed air to keep appliance clean and safe for use. Never clear ports or other openings with toothpicks or other article that will break and block the ports.
- If carbon deposits develop, remove the reflector and flame screen and clean them with soap water. Do not paint the flame screen, control panel or reflector.
- Cover the burner unit with the supplied protective cover when the heater is not in use. Wait until the heater is completely cooled down before covering.
- In a salt-air environment, such as near an ocean, corrosion occurs more quickly than normal. Check frequently for corroded areas and repair them promptly.

WARNING

1. Do not perform maintenance right after the heater has been turned off, wait until the temperature has cooled down.
2. Do not expose the pilot, controllers and parts underneath the burner to water. Do not use the heater if any of these parts are exposed to water until the appliance is inspected or repaired by a qualified service person.

PROBLEM CHECK LIST

<u>PROBLEM</u>	<u>PROBABLE CAUSE</u>	<u>SOLUTION</u>
There is no spark at pilot when the control knob is pressed in and turned counterclockwise to Pilot position	<ul style="list-style-type: none"> • Igniter electrode positioned wrong. • Igniter electrode broken. • Igniter cable pinched or broken. 	<ul style="list-style-type: none"> • Replace igniter electrode. • Replace electrode. • Free electrode cable. If damaged, replace it.
There is spark but no ignition when the control knob is pressed in and turned counterclockwise to Pilot position	<ul style="list-style-type: none"> • Gas supply turned off. • Control knob not in pilot position. • Control knob not pressed in while in pilot position. • Pilot is clogged. • Air in gas lines. 	<ul style="list-style-type: none"> • Turn on the gas supply. • Turn variable control knob to pilot position. • Press in control knob while in pilot position. • Call a qualified service person or your gas supplier. • Purge air from lines by pressing the control knob continuously until there's a faint gas smell.
Pilot lights but flame goes out when control knob is released	<ul style="list-style-type: none"> • Control knob not pressed long enough. • Pilot flame not touching the thermocouple. Problem could be result of one or both of the following: <ul style="list-style-type: none"> - Partially clogged pilot injector. - Low gas pressure. • Thermocouple damaged. • Thermocouple connection is loose at gas control valve. • Gas control valve damaged. 	<ul style="list-style-type: none"> • After pilot lights, keep control knob pressed in approx. 30 seconds. • Contact a qualified service person or your gas supplier. • Replace thermocouple by qualified service person. • Hand tight until snug then tighten ¼ turn with a wrench. • Replace gas control by qualified service person.
Burner does not light after pilot is lit	<ul style="list-style-type: none"> • Burner injector clogged. • Low gas supply pressure. 	<ul style="list-style-type: none"> • Clean burner injector. • Call your gas supplier.
Burner flame goes off immediately after ignition	<ul style="list-style-type: none"> • Low gas pressure 	<ul style="list-style-type: none"> • Let the pilot flame stay lit for 10 minutes before setting variable knob to LO.
Delayed ignition	<ul style="list-style-type: none"> • Main burner carry over ports clogged. • Low gas supply pressure 	<ul style="list-style-type: none"> • Clean main burner ports. • Call your gas supplier.
Inadequate combustion on burner	<ul style="list-style-type: none"> • Not enough air. 	<ul style="list-style-type: none"> • Check air passageways and burners for dirt and debris, and clean with compressed air.

<u>PROBLEM</u>	<u>PROBABLE CAUSE</u>	<u>SOLUTION</u>
Burner flame is low	<ul style="list-style-type: none"> • Supply hose is bent or twisted • Blockage in burner injector 	<ul style="list-style-type: none"> • Straighten hose and perform leak test on hose by a qualified service man. • Clean or replace burner Injector by qualified service person.
Emitter glows uneven	<ul style="list-style-type: none"> • Blockage in burner injector • Base is not on a level surface • Low gas pressure 	<ul style="list-style-type: none"> • Clean or replace burner injector by a qualified service man. • Place heater on a level surface. • Replace cylinder with a new cylinder.
Slight smoke and odor during initial operation	<ul style="list-style-type: none"> • Residue from manufacturing processes. 	<ul style="list-style-type: none"> • Will stop after approx. 30 minutes of operation.
Thick black smoke	<ul style="list-style-type: none"> • Blockage in burner 	<ul style="list-style-type: none"> • Turn off the heater and let it cool. Remove blockage and clean burner inside and outside by a qualified service man.
Heater produces a whistling noise when burner is lit.	<ul style="list-style-type: none"> • Air passageways blocked. • Air in the gas line. 	<ul style="list-style-type: none"> • Check minimum installation clearances and air passageways for debris. • Operate burner until the air is completely purged.
Heater produces a clicking noise just after burner is lit or turned off.	<ul style="list-style-type: none"> • Metal expanding and contracting, respectively. 	<ul style="list-style-type: none"> • This is common with heaters. If noise is excessive, contact a qualified service person.
Gas odor even when control knob is in OFF position	<ul style="list-style-type: none"> • Gas leaks. • Gas control defective. 	<ul style="list-style-type: none"> • Locate and correct leaks immediately. • Replace gas control by a qualified service man.
Gas odor during combustion	<ul style="list-style-type: none"> • Foreign matter in gas or on burner ports. • Heater burning vapors from paint, impurities in air. • Gas leakage from: <ul style="list-style-type: none"> - Regulator and hose connection. - Valve and pipes connection. - Pipes 	<ul style="list-style-type: none"> • Check gas passageway and burner. • Stop storing and using odor-causing products near the heater. • Locate and correct leaks, or contact your gas supplier.
Carbon build-up	<ul style="list-style-type: none"> • Dirt or film on reflector and flame screen 	

- Clean reflector and flame screen.

Company:Changzhou Hi-Seasons Products Co.,Ltd.

Address: No.72Chunqiu Road,Lujiaxiang Village,Niutang
Town,Wujin ,Changzhou, 213168,Jiangsu,PR
China

Retail trader:

Address:

Telephone number: